

FEATURES

Design

Unit Design

- Compact design reduces unit size up to 25% of the original Vector Rotary's size. **Now even more Compact - the new 2003 redesign** reduces the size of 10-16K units even further, approximately one inch in both width and depth.
- Return air filters are **now included**, and are held in place by new filter rails.
- **Patented** design #5,848,536 provides increased gross cooling capacity and increased dehumidification.
- Unique compressor and reversing valve mounting reduces vibration.
- Built-in carrying handle provides ease of installation.
- Blowers are fully insulated and rotatable.
- Passport® I/O circuit board operates the new **Elite™** and Passport I/O displays (model VCD only). Controls are sold separately.

Electrical Box

- Electrical box is installed on unit, within the footprint dimensions, eliminating additional installation labor and space required.
- Completely enclosed, water resistant box protects electrical components.
- Internal field wiring connections meet CE Low Voltage directive.

High Efficiency Components

- High efficiency rotary compressors provide reduced amperage, quieter operation, less weight and increased reliability.
- Condenser coil constructed of spiral, fluted cupronickel encased in a copper shell provides maximum heat transfer and high corrosion resistance to seawater flow.
- Evaporator coil utilizes enhanced fin design and rifled copper tubing provides maximum capacity.
- There are two compact models in the self-contained Vector Compact Series - VCD and VCM. Each uses a different control. For details, see specifications.

Quality Assurance

- **Three year limited warranty** when used with the Elite or Passport I/O Controls.
- Each unit is pre-charged, leak checked and test run in all operating modes.
- Charge Guard® protection provides sealed access ports, ensuring environmental protection and system integrity.
- All units meet or exceed applicable ABYC and U.S. Coast Guard regulations, CE Directives and general Air Conditioning and Refrigeration Industry (ARI) standards.

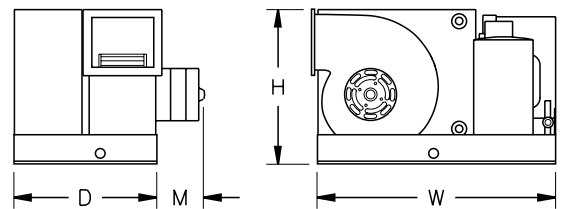

SPECIFICATIONS

Model <sup>(1)</sup>	VC*5K/1		VC*7K/1			VC*10K/1			VC*12K/1			VC*16K/1			VC*24K/1 <sup>(4)</sup>	
Capacity (BTU/H) <sup>(2)</sup>	5,000		7,000			10,000			12,000			16,000			24,000	
Voltage (VAC)	115	220-240	115	230	220-240	115	230	220-240	115	230	220-240	115	230	220-240	230	220-240
Cycle (Hz) <sup>(3)</sup>	60	50	60	60	50	60	60	50	60	60	50	60	60	50	60	50
Full Load Amps (FLA) cool <sup>(2)</sup>	5.2	2.7	6.3	2.8	3.2	8.9	4.2	4.5	10.9	4.9	4.8	11.7	5.8	5.7	7.1	8.1
Full Load Amps (FLA) heat <sup>(2)</sup>	6.3	3.2	7.8	3.6	3.7	11.1	5.3	5.3	12.9	6.0	5.8	14.7	7.2	7.0	9.7	10.6
Locked Rotor Amps (Comp) <sup>(2)</sup>	30.1	17.7	36.2	17.7	16.5	45.6	22.2	22.2	58.4	27.9	22.2	67.0	29.0	32.0	54.0	56.0
K.V.A. (Kilo-Volt-Amps) <sup>(2)</sup>	0.7	0.8	0.9	0.9	0.9	1.3	1.2	1.3	1.5	1.4	1.4	1.7	1.7	1.7	2.2	2.5
Max. Circuit Breaker (Amps) <sup>(2)</sup>	15	10	20	10	10	30	15	15	40	20	15	40	20	20	35	40
Min. Circuit Ampacity (Amps) <sup>(2)</sup>	11	7	14	7	7	19	9	10	24	12	10	26	14	13	21	24
Refrigerant R-22 (oz/g) <sup>(5)</sup>	8.0/227		10.0/283			10.5/298			11.0/312			15.0/425			16.0/454	
<b>Unit Dimensions (in/mm)</b>																
Height - Evaporator	11.25/286		11.50/292			12.25/311			13.00/330			13.63/346			18.00/457	
Height - Blower <sup>(6)</sup>	10.50/267		12.25/311			13.50/343			13.63/346			13.63/346			19.25/489	
Width	16.50/419		18.00/457			19.25/489			19.25/489			19.25/489			24.75/629	
Depth	9.00/229		9.63/245			9.63/245			9.63/245			11.38/289			15.25/387	
Motor Overhang <sup>(6)</sup>	3.75/95		3.25/83			3.75/95			3.75/95			4.00/102			3.50/89	
Min. Duct Size Dia.	4/102		5/127			6/152			6/152			7/178			8/203	
Net Weight (lbs/kg)	42.0/19.1		48.7/22.0			54.3/24.6			56.3/25.5			63.8/28.9			120.0/54.4	
Gross Weight (lbs/kg)	51.4/23.3		58.0/26.3			63.0/28.6			65.0/29.5			73.0/33.1			130.0/58.9	

<sup>(1)</sup> Add a 'Z' or 'Z50' before the '1' in the model number for 230V or 220V/50Hz units respectively. Examples: VCD7K/1 = 115V, VCD7KZ/1 = 230V, VCD7KZ50/1 = 220V/50Hz.  
<sup>(2)</sup> BTU and electrical data are based on a 45°F/7.2°C evaporator and 100°F/37.8°C condenser in cool mode, and a 45°F/7.2°C evaporator and 130°F/54.4°C condenser in heat.  
<sup>(3)</sup> Standard 60Hz units may be operated at 50Hz and reduced voltages. However, there will be a 17% reduction in capacity in that application. In order to achieve full capacity at 50Hz, a dedicated 50Hz unit must be used. **Note:** 50Hz units must not operate at 60Hz.  
<sup>(4)</sup> Contains high efficiency scroll compressor.  
<sup>(5)</sup> Alternative "Environmentally Friendly Green Gas" refrigerants available on request.  
<sup>(6)</sup> Blower may be rotated downward to below evaporator height. (See other side.)  
<sup>(7)</sup> The depth of the VC-10K-HV and VC-12K-HV is 10.50/267 (in/mm).  
<sup>(8)</sup> Motor is inside blower on HV units, however, allow 1.00/25 (in/mm) for blower ring flange on that side.

\*D = Elite or Passport I/O Control (VCD), M = Mechanical Control (VCM)

# Installation Guidelines for Vector Compact

When choosing the proper model **Vector Compact** self-contained unit, primary consideration should be given to calculated BTU loads and available power supply. Special consideration should be given in determining the reverse cycle heating capacities under anticipated conditions. Reverse cycle operation is affected by the seawater temperature. As it decreases, the units heat transfer capacity also decreases and proportionately affects the output of warm air. It is not recommended that the unit be operated in the heat cycle with water temperatures below 40°F (4.4°C).

The location of the **Vector Compact** self-contained unit should be dry and accessible for service. Placement of the unit should be adjacent to a low return air access from the area to be conditioned. The unit should be installed with the proper fasteners and secured to a horizontal surface sufficient for the unit weight and torsional load from the vessel's movement.

Never install your air conditioner in bilge or engine room areas. Insure that the selected location is sealed from direct access to bilge and/or engine room vapors. Do not terminate condensate drain lines within three (3) feet of any outlet of engine or generator exhaust systems, nor in a compartment housing an engine or generator, nor in a bilge (vapors can travel up the drain line), unless the drain is connected properly to a sealed condensate or shower sump pump. Failure to comply may allow bilge or engine room vapors to mix with the air conditioner's return air and contaminate living areas.

Grilles should be sized according to Marine Air design standards. Install the return air grilles low and the supply air grilles high. Return air grilles must have removable filters installed if the filter on the unit is removed.

Ducting should be sized according to unit specifications. All ducting should be installed to be as smooth, straight and taut as possible, avoiding any unnecessary bends or loops. Once ducting runs are positioned properly they should be securely fastened to avoid shifting due to motion of the vessel.

Plastic vacuum-formed and insulated aluminum transition boxes are available for proper air flow direction into any cabin or area. Ducting should be properly secured to these transition boxes to prevent air flow leakage. Built-in plenums or chases must be sized properly, completely sealed and insulated.

Reinforced marine grade hose must be used for the seawater circuit. All fittings must be double hose clamped, reversing the clamps. The hose should be routed upward from the thru-hull intake, sea cock, strainer, pump, and to the condensing unit to prevent air locks in the centrifugal seawater pump.

Circuit breakers and wire gauge must be sized according to marine design standards. Only stranded tinned copper wire should be used. All equipment should be properly grounded and bonded. Ensure that power supply is turned off before opening electrical box.

In keeping with regulations set forth by the EPA, only certified technicians should perform service on, or make adjustments to, the refrigerant circuit.

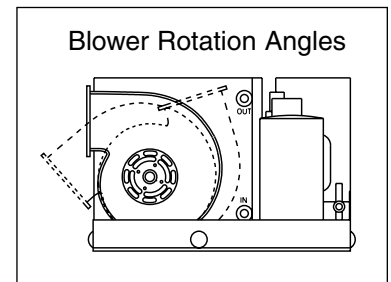
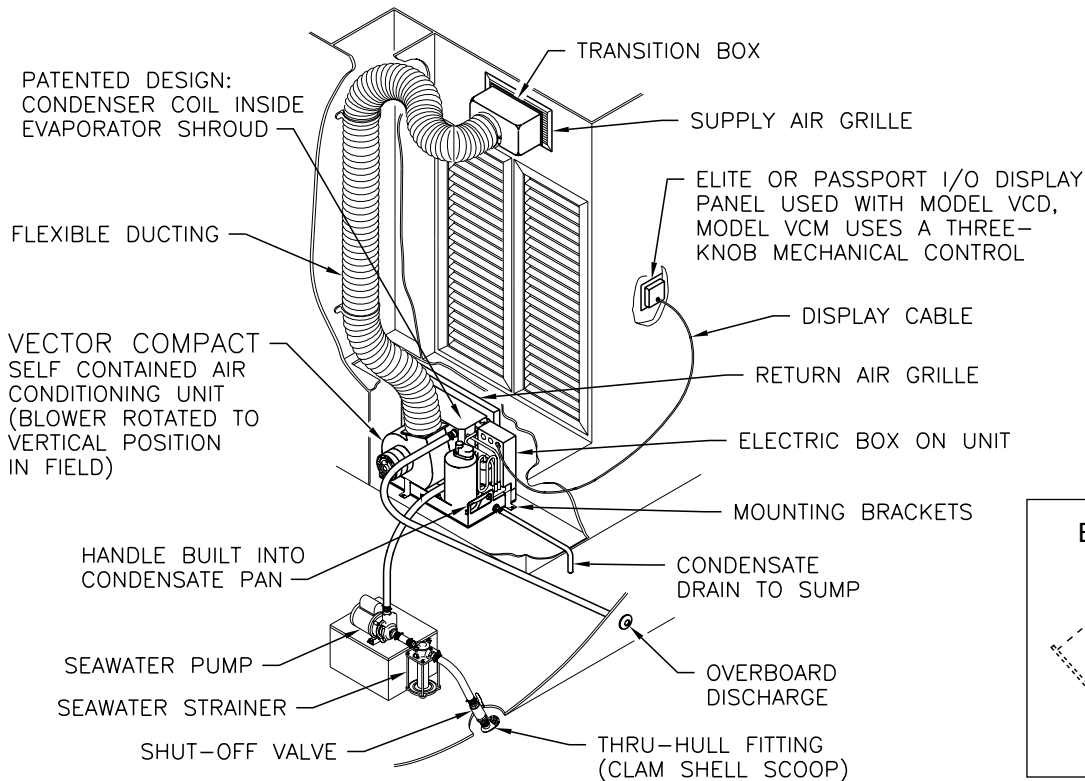

In the interest of product improvement, Taylor Made Environmental's specifications and design as outlined herein are subject to change without prior notice.



Sold and Serviced By:

**Taylor Made Environmental, Inc.**

2000 N. Andrews Ave. Ext. • Pompano Beach, FL USA 33069-1497 • 954-973-2477 • Fax: 954-979-4414 • sales@tmenviro-fl.com • www.tmenviro.com  
 P.O. Box 15299 • Richmond, VA USA 23227-0699 • 804-746-1313 • Fax: 804-746-7248 • sales@tmenviro-va.com

Fleets Industrial Estate • 26 Willis Way • Poole, Dorset • England BH15 3SU • +44 (0)870 3306101 • Fax: +44 (0)870 3306102 • sales@tmenviro-eu.com

©Taylor Made is a registered trademark of Nelson A. Taylor Co., Inc.; the Taylor Made Group logo is a trademark of Nelson A. Taylor Co., Inc.; the Marine Air Systems logo and Vector Compact and Passport names are registered trademarks, and the Elite name and Taylor Made Environmental logo are trademarks of Taylor Made Environmental, Inc.

A Member of  
**THE TAYLOR MADE GROUP.**

Revised: 06-25-03 L-2262